



## SPM-4000-DC GUARDIAN INFINITY SPACE PRESSURIZATION MONITOR AND DUAL CONTROLLER

### Description

The **Guardian Infinity** is a true differential space pressure measurement system engineered to combine the operability of today's microprocessor technology with state-of-the-art, industrial grade, highly accurate, ultra low range, differential pressure sensing cells. The combination of these two technologies ensures exceptional long-term stability and  $\pm 0.25\%$  measurement accuracy.

Field configuration of engineering units, operating mode, operating range, process noise filtering, alarm set points, etc, are performed via password protected intuitive menus that are accessed through the integral six button touch pad. Device monitoring and configuration can also be performed by a building management system through either a LonWorks® or BACnet®-MS/TP communication network and through a local IR communication port using a laptop or handheld PDA. An additional network communication port is available for connection to Paragon Controls' **Guardian RPM**, a remote pressure monitor that can be located at a nurse's station. The front panel includes an 8 line graphic display for local indication of the space pressure and device configuration, LED indication of operational mode and status, and an audible alarm with alarm acknowledge switch.

The **Guardian Infinity** offers 2 controller loops that utilize a proprietary algorithm which results in true three mode control incorporating proportional band, integral (reset) and inverse derivative (P, I, 1/D) controller functionality and tuning. The controller will provide responsive modulation of a control damper or variable speed drive guaranteeing a stable space pressure is maintained.

### Features

- True differential pressure sensing assuring no sensor fouling due to airborne particulate
- Ultra low pressure measurement down to one ten-thousandth of an inch water column (0.025Pa)
- High accuracy and long-term stability
- LonWorks® and BACnet® certified by an independent testing laboratory
- Available in nine full scale ranges
- Positive and negative pressure monitoring
- Eight line graphic display
- LED's to indicate normal or alarm status
- Audible local alarm and alarm acknowledge button
- Time delay to prevent nuisance alarms
- Simple field configuration and adjustment of operational mode, alarm and time delay values, and controller setpoint
- Form C SPDT relay for activation of a remote alarm
- Two three-mode controller (P, I, 1/D) loops with door interlock feature programmable to either freeze controller output or bias output by a predetermined % F.S. value whenever a door into the space is opened.
- Optional wash-down compliant to International Protection Rating Standard IP64B

## SPM-4000-DC Technical Specifications

### 1. Full Scale Ranges

#### Bidirectional

- ±0.05 in. of water (±12.45 Pa)
- ±0.10 in. of water (±24.91 Pa)
- ±0.25 in. of water (±62.27 Pa)
- ±0.50 in. of water (±124.54 Pa)
- ±1.00 in. of water (±249.09 Pa)

### 2. Accuracy

±0.25% F.S. including linearity, hysteresis, deadband and repeatability

### 3. Temperature Effect

Zero: ±0.025% of transducer full span per °F  
Span: ±0.025% of transducer full span per °F

### 4. Temperature Limits

Operating: 32 to 122°F (0 to 50°C)  
Storage: -20 to 158°F (-29 to 70°C)

### 5. Overpressure Limits

Proof Pressure: 15 psid (0.3447 bar)  
Burst Pressure: 25 psid (0.689 bar)

### 6. Humidity Limits

0 to 95% RH, non-condensing

### 7. Stability

Maximum Change F.S./Yr.: ±0.5%

### 8. Mounting Position Effect

Below 0.5 in. of water (124.5 Pa):  
≤ 0.25% full scale  
Above 0.5 in. of water (124.5 Pa):  
≤ 0.10% full scale

### 9. Span and Zero Adjustments

Performed by front panel push buttons

### 10. Display Low Pass Filter

Response time to reach 98% of a step change is menu adjustable by entering a value of 0 to 100 seconds

### 11. Output Low Pass Filter

Response time to reach 98% of a step change is menu adjustable by entering a value of 0 to 100 seconds

### 12. Programmable Controller Parameters

Menu selectable values for Proportional band, Integral (reset), and Inverse Derivative (P-I-<sup>1</sup>/<sub>D</sub>)

### 13. Control Accuracy

±0.5% F.S.

## Indication

### 14. Display

A backlit, graphical LCD providing 8 lines of data display. Also used for local programming.

### 15. High and Low Alarm Status

Indicated by green/red LEDs, flashing text on display, and relay outputs

## Inputs/Outputs

### 16. Analog Inputs (Field Selectable)

- a. Room 1 Controller Setpoint (0-10vdc/4-20mA)
- b. Room 2 Controller Setpoint (0-10vdc/4-20mA)

### 17. Analog Outputs (Field Selectable)

- a. Room 1 Controller Output (0-10vdc/4-20mA)
- b. Room 2 Controller Output (0-10vdc/4-20mA)

### 18. Digital Inputs

- a. Pos./Neg./Off Room Select
- b. Controller "System Start"
- c. Room 1 Door Interlock
- d. Room 2 Door Interlock

### 19. Relay Outputs

Remote Alarm: single (1 form C) dry contacts rated for 1 amp at 30 VDC / 3 amps at 125 VAC / 2 amps at 250 VAC resistive load

## Communication

### 20. Network

LonWorks®  
BACnet MS/TP®

### 21. Local

IR communication via PC or PDA

## Variables

### 22. Room Identifier

Accepts 16 alpha/numeric characters

### 23. Operation Mode

Off/Negative  
Off/Positive  
Positive/Off/Negative

### 24. Filters

Output: 0 to 100 seconds  
Display: 0 to 100 seconds

### 25. Engineering Units

Inch w.c.  
Pa  
KPa  
mm of w.c.

### 26. Alarm Values

Positive High Alarm Value  
Positive Low Alarm Value  
Negative High Alarm Value  
Negative Low Alarm Value  
Alarm Delay Value

### 27. Audible Alarm

Selection of ON/OFF

### 28. Alarm Delay

Delays alarm activation after an alarm event occurs from 0 to 9999 seconds. The default is 30 seconds.

### 29. Field Password

Accepts up to 5 numeric characters

### 30. Analog Output/Controller Outputs

Field selectable 4 to 20mA or 0 to 10 VDC

## Power

### 31. Power Supply

20 to 28 VAC (50/60HZ)

### 32. Power Consumption

Standard Unit: 5.16 VA at 24 VAC  
Full Options: 6.48 VA at 24 VAC

### 33. Circuit Protection

Power input is isolated and supplied with a resettable fuse

### SPM-4000-DC Ordering Information

SPM-4

DC -

**Options:**

- 1 = LonWorks® Communication with BAS
- 2 = BACnet®-MS/TP Communication with BAS
- 3 = Wash-Down Compliant IP64B
- 4 = Surface Mount Electrical Box
- 5 = Air Tight Flush Mount Electrical Box

*Note: For multiple options, separate each option code with a dash*

**Operating Mode:**

- 1 = Off/Negative
- 2 = Off/Positive
- 3 = Positive/Off/Negative

**Controller Output:**

- 1 = 4-20 mA
- 2 = 0-10 VDC

**Full Scale Range:**

- Bidirectional
- 1 = ±0.05 in. of water (12.45 Pa)
- 2 = ±0.10 in. of water (24.91 Pa)
- 3 = ±0.25 in. of water (62.27 Pa)
- 4 = ±0.50 in. of water (124.54 Pa)
- 5 = ±1.0 in. of water (249.09 Pa)
- 6 = Other (Specify Range)

### SPM-4000 Dimensions

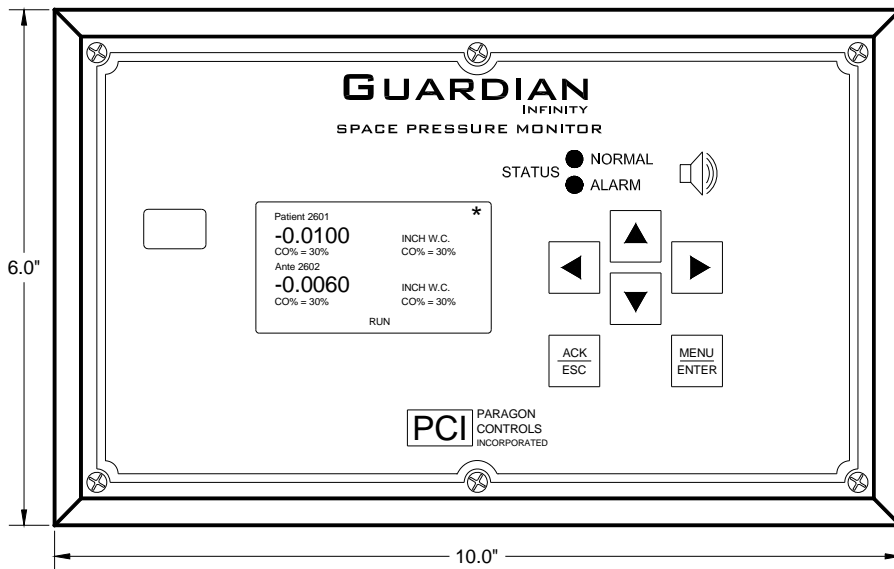

SPM-4000 Typical Installations

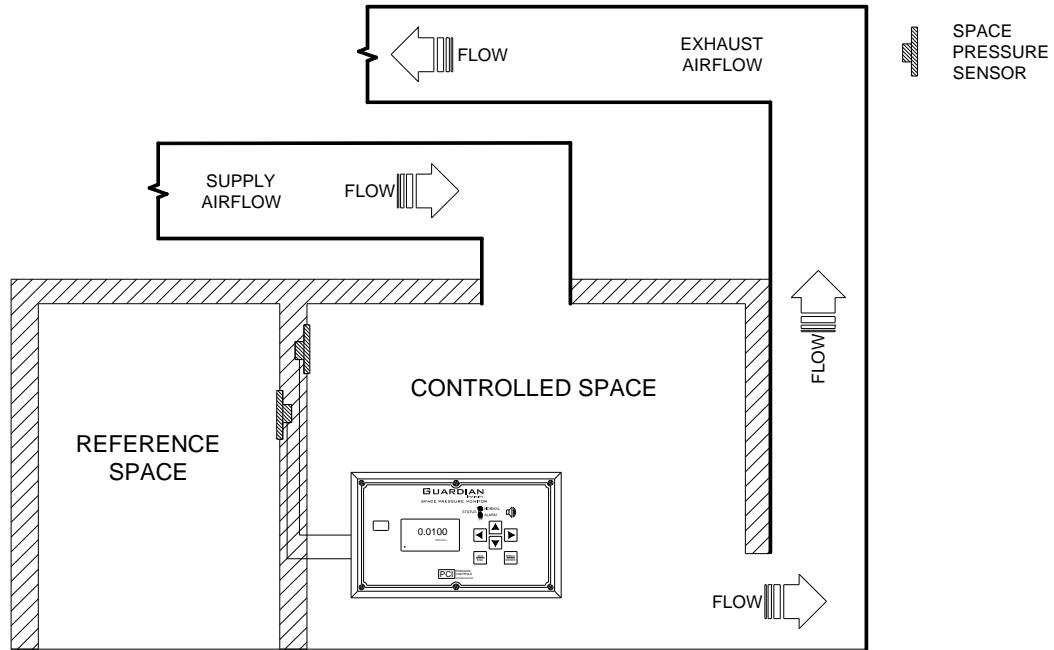

Figure 1: Pressure Monitoring Only

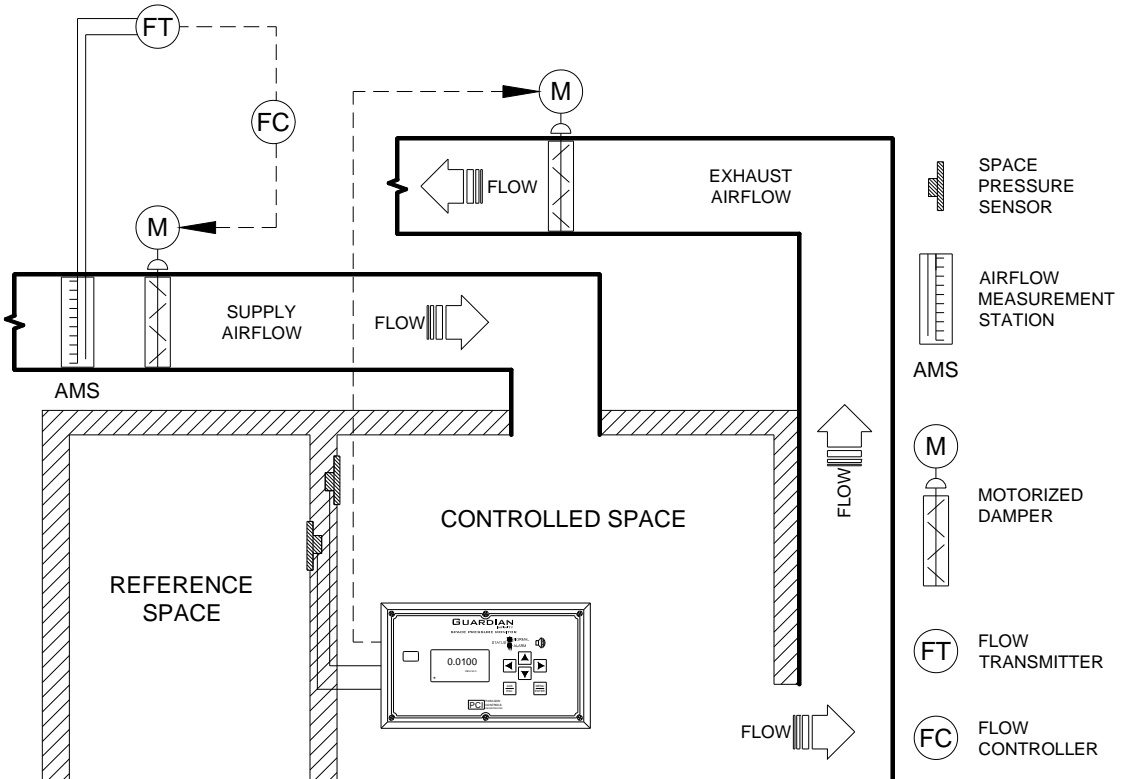

Figure 2: Constant Volume with Pressure Control

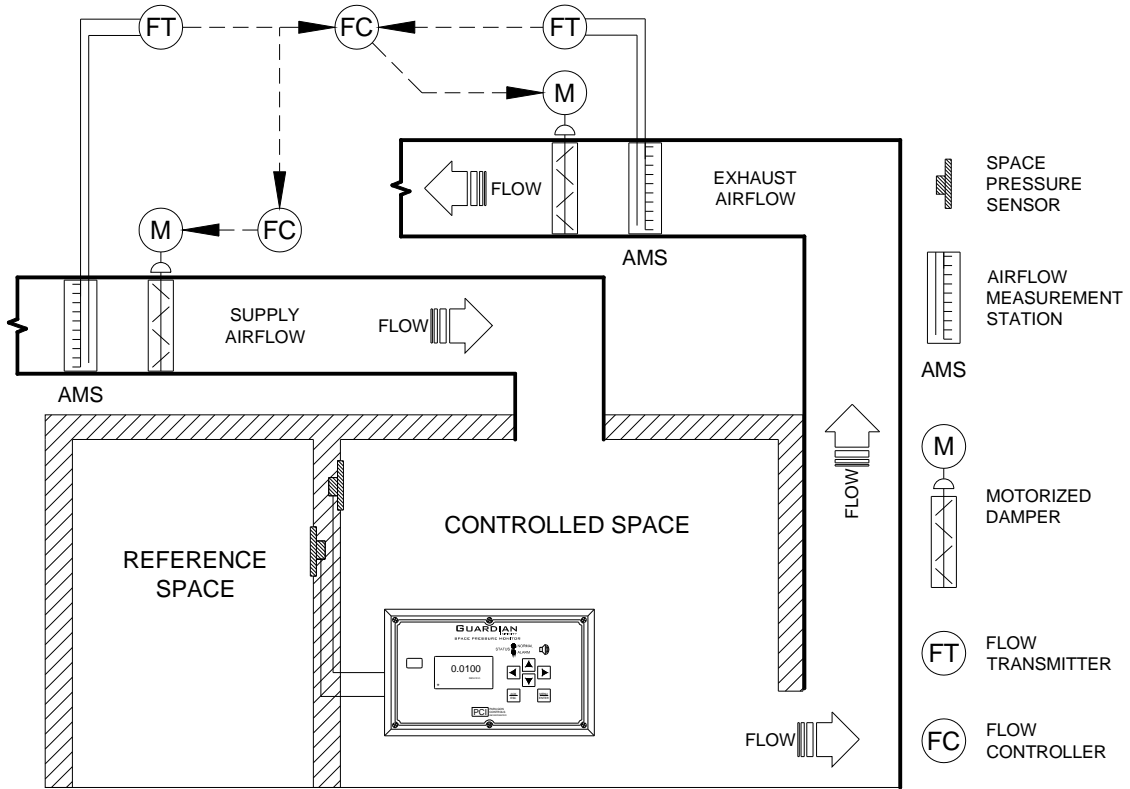

Figure 3: Volumetric Offset Control

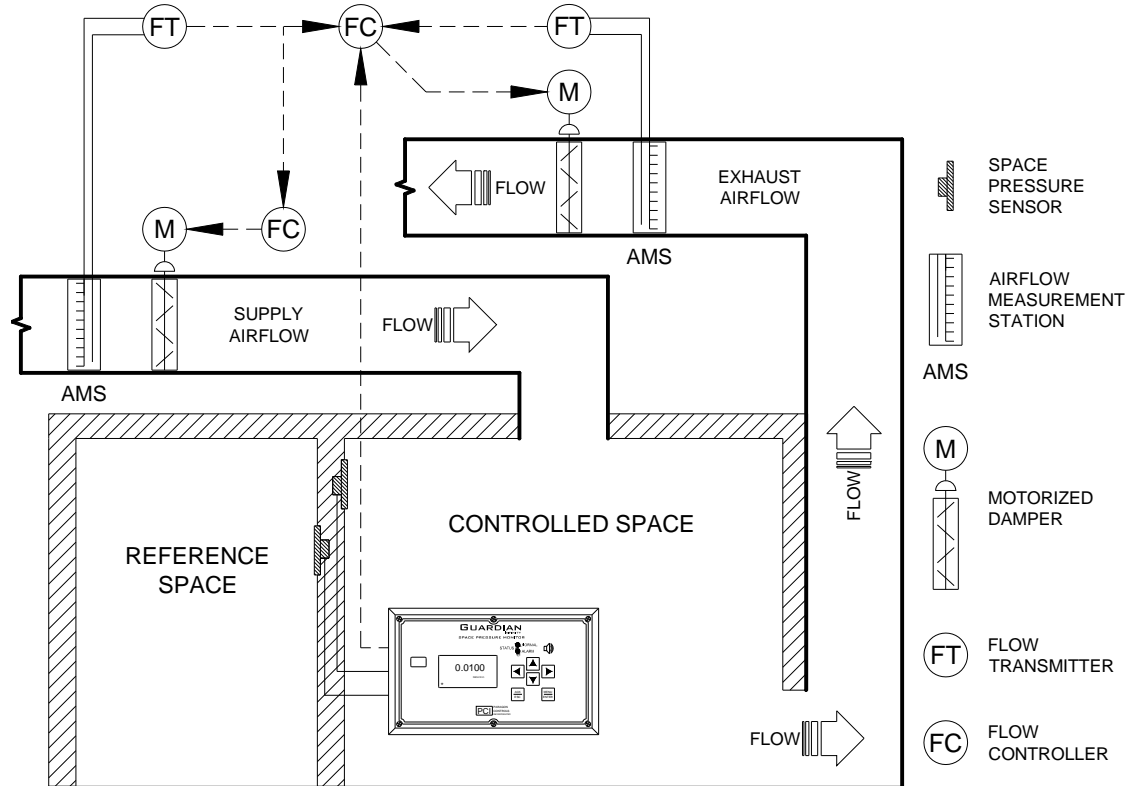
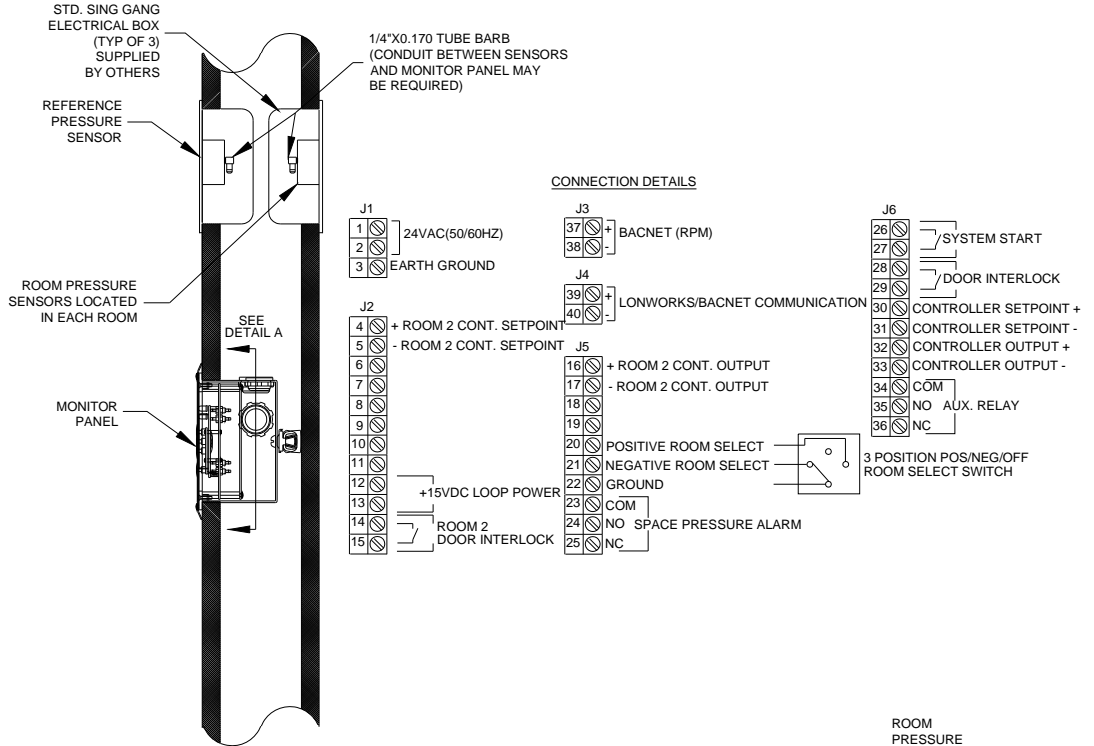
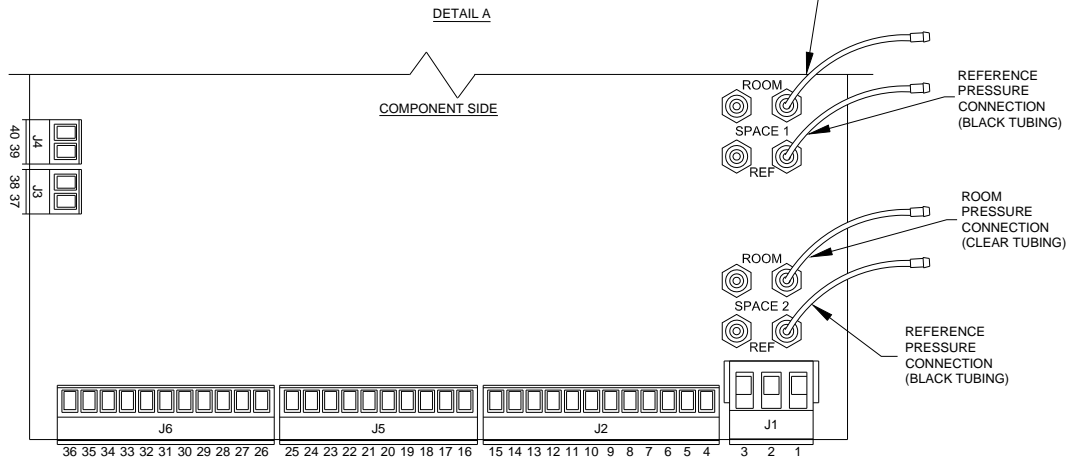
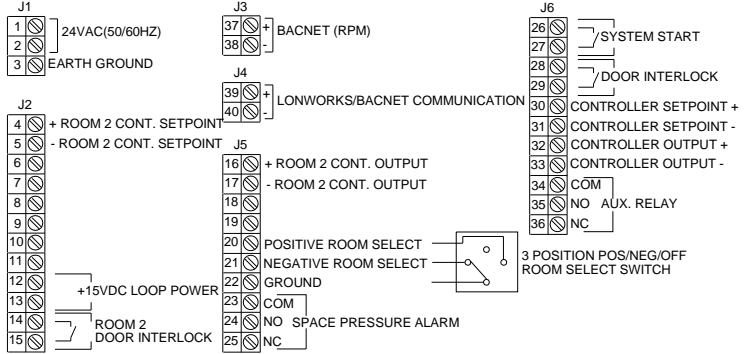

Figure 4: Cascade Pressure Control

# SPM-4000-DC Installation and Field Connections



**CONNECTION DETAILS**



## SPM-4000-DC Specification Guide

### Space Pressure Monitor and Alarm Systems

1. Provide where indicated and/or scheduled a space pressure monitor and alarm system (SPM) capable of measuring the differential pressure between two spaces and alarming if any of the required control conditions are not maintained.
2. The SPM shall measure the differential pressure between two spaces using industrial grade differential pressure transducers meeting the following performance criteria. Systems using air velocity measurement between two spaces which imply a specific space pressure exists are not acceptable.
  - Accuracy:  $\pm 0.25\%$  F.S. including linearity, hysteresis, deadband and repeatability
  - Temperature Effects:  $0.025\%$  F.S./deg F
  - Stability – Maximum Change F.S./Yr:  $\pm 0.5\%$
  - Over-pressure: 15 psid proof/25 psid burst
3. Each SPM shall have local high intensity LED indicating lights identifying either normal or alarm status of the space being monitored, a local audible alarm, an alarm acknowledge button, and local indication of the measured space pressure down to one ten-thousandth of an inch of water (0.025 Pa)
4. Each space shall have a dedicated SPM that shall be capable of both standalone operation as well as full integration into the building management system (BMS). The SPM shall also be capable of local communication and configuration via a handheld device having an integral and compatible IR communication port or via integral pushbuttons. SPM monitoring and configuration shall be performed through [LonWorks®] [BACnet®-MS/TP communication networks] and/or through local IR communication between the SPM and compatible portable device. The operational mode (Positive/Negative/Off) shall be selectable via the use of a remote mounted key switch.
5. The SPM shall be capable of controlling either a modulating control damper or fan variable speed drive so as to maintain the required space pressure at a constant value. The SPM shall have menu selectable control mode values and be capable of "In Operation" controller tuning of proportional band, reset (integral), and inverse derivative (P,I, 1/D) to match system dynamics. The controller shall also be provided with the following:
  - Auto/Manual control output selection.
  - Local or remote adjustment of the required differential pressure setpoint value.
  - Door interlock feature programmable to either freeze controller output or bias output by a predetermined % F.S. value whenever a door into the space is opened.
  - Control accuracy of  $\pm 0.5\%$  F.S.
6. The SPM shall be capable of monitoring two spaces and alarming if any of the required control conditions are not maintained.
7. The SPM shall provide a field selectable 4-20 mA or 0-10 VDC analog controller output signals as well as a form C SPDT binary alarm relay for remote monitoring and alarming capability.
8. Selections and adjustments that may be made at the jobsite shall include Positive and/or Negative pressurization mode selection; high and low pressure alarm activation values; alarm delay value; controller tuning; and controlled space pressure setpoint value.
9. All of the SPM system components shall meet International Protection Rating Standard IP64B for wash-down and intrusion compliance to allow for good housekeeping practices.
10. Each SPM shall include a pressure monitoring module with mounting box and three space pressure sensors. All components of the space pressure monitoring system shall be designed for both flush mounting and surface mounting, and shall be furnished to comply with the specified project requirements.

### Manufacturer

1. The SPM system manufacturer shall have a minimum of five (5) years of experience in space pressure monitoring and control, and shall be willing and able to provide a user list, with contact information, upon request.
2. The space pressure monitoring system shall be the Guardian Infinity Model SPM-4000-DC as manufactured by Paragon Controls Incorporated, Santa Rosa, California, telephone (707) 579-1424.
3. Alternatives requesting acceptance "as equal" less than 60 days prior to bid date or products submitted in non-conformance with the requirements of this specification will not be considered. For any product to be considered for substitution a written detailed exception/compliance document shall be submitted to the Engineer prior to any consideration for approval.

